



The Fairport Municipal Commission (FMC) does not supply single-phase or three phase meter sockets for our customers. A specification sheet showing approved sockets is attached. Before providing service, the FMC will require the following:

1. A valid electrical permit from either the Town of Perinton or the Village of Fairport, depending on the location of the work site.
2. A trench inspection by the FMC for all underground services.
3. An electrical inspection by either:
Middle Department (454-5191)
Commonwealth Inspection Agency (624-2380)
4. New service locations: The account information including deposit must be set up with the FMC electrical billing office (223-0440).

585-223-9500

FAIRPORT MUNICIPAL COMMISSION APPROVED METER SOCKETS BY APPLICATION

For all Single Phase 100A, 150A, 200A, Overhead and Underground Services

Description 200 AMP Overhead/Underground:

1-Position, 200 AMP, top opening for a standard 1" to 2 ½", 4 jaw socket with horn type bypass and provisions for later installation of a 5th jaw. Line/load connections, lay-in style, #2 through 250 MCM. At least one grounding terminal and ringless latch type cover.

Description – 200 AMP Multiple-Gang, Overhead/Underground 1 Phase, 3 Wire, 120/240V:

1, 2, 3, 4, 5 and 6 position, 200 AMP capacity per position, hub opening for standard 1" to 2 ½" entry, 4 jaw socket with horn bypass and provisions for later installation of a 5th jaw. Bussed line conductor, load conductor lay-in style for up to #4/0 Awg. At least one grounding terminal per position and ringless latch type cover.

Description – 320 AMP Overhead/Underground, 1 Phase, 3 Wire, 120/240V:

1 – Position, 320 AMP, top or bottom opening for large size hub. 4-jaw socket with safety shield and provision for 5th jaw. Non-removable bypass lever, single 3/8" studs line/load. At least one grounding terminal and ringless latch type cover.

See Page 3 for complete list of Part Numbers

Manufacturer →	Milbank	Cutler Hammer	Murray	Square D	Siemens/ Landis & GYR	Cooper B-Line
125 amp 4 term 1p3w (See Note 2)	CAT# U7487-RL-TG-KK	N/A	N/A	N/A	N/A	N/A
200 amp 4 term 1p3w	CAT# U7040-RL-TG-KK	CAT# UHTRS213CCH	CAT# RB198AR	CAT# UHTRS213B	CAT# UAT417-OPRG	N/A
2 gang 4 term 1p3w	CAT# U1252-R-KK	CAT# UEHT2R2302UCH	N/A	N/A	CAT# UA2717-YPRG	N/A
3 gang 4 term 1p3w	CAT# U1253-R-KK	CAT# UEHT3R2302UCH	N/A	N/A	CAT# UA3717-YPRG	N/A
4 gang 4 term 1p3w	CAT# U1254-R-KK-EX	CAT# UEHT4R2302UCH	N/A	N/A	CAT# UA4719-YPRG	N/A
5 gang 4 term 1p3w	CAT# U1255-R-KK-EX	CAT# UEHT5R2302UUCH	N/A	N/A	CAT# UA5719-KPRG	N/A
6 gang 4 term 1p3w	CAT# U1256-R-KK-EX	CAT# UEHT6R2302UUCH	N/A	N/A	CAT# UA6719-KPRG	N/A
320 amp 4 term 1p3w w/bypass	UG CAT# U1797-X OH/UG CAT# U2448-X	CAT# UTH4330TCH	CAT# RK178A	CAT# UTH4330T	CAT# 48104-02RG	N/A
200 amp 7 term 3p4w w/bypass(See note 1)	CAT# U7423-RXL	CAT# UETH7213UCH	CAT# RH178GRJNU	CAT# UTH7213T	CAT# 40407-02LL	N/A
400 amp 1p3w 120/240V 3p4w 120/208V 3p4w 120/240V (w/o VT's)	CAT# CT242411-SC 11Dx24Wx24H NEMA 3R	N/A	N/A	N/A	N/A	CAT# 303012RHC Cabinet & N3030P Back Panel
400 amp 3p4w 277/480V (w/VT's)	CAT# 363612-CT3R 12Dx36Wx36H NEMA 3R	N/A	N/A	N/A	N/A	CAT# 363612RHC Cabinet & N3636P Back Panel
800 amp (all voltages)	CAT# 483612-CT3R 12Dx48Wx36H NEMA 3R	N/A	N/A	N/A	N/A	CAT# 363612RHC Cabinet & N3636P Back Panel
20 amp 6 term 1p3w CT (See note 1)	CAT# UC7478-RL	N/A	N/A	N/A	N/A	N/A
20 amp 13 term 3p4w CT (See note 1)	CAT# UC7445-RL	N/A	N/A	N/A	N/A	N/A
6 term test switch (required for 20 amp 6 term box) (See note 1)	CAT# TS07-0105	N/A	N/A	N/A	N/A	N/A
13 term test switch (required for 20 amp 13 term box) (See note 1)	CAT# TS10-0109	N/A	N/A	N/A	N/A	N/A
Metal Security Cover (outdoor installations) Of 3 Phase Meter Box	Metering Devices Ph #330-455-0301 Cat #686-2474-11 Note: Specify supplied with the #500-3590-CLH clear lexan cover Local Vendor: Gottogo Elec Ph #585-768-2650	N/A	N/A	N/A	N/A	N/A

Note #1 :The contractor shall consult with the FMC Meter Department 223-9500 (ext. 107) before ordering any 3-phase meter boxes.

Note #2 :Time Warner , Frontier Telephone Power Supplies, NYSDOT and County Traffic Signals only, 240 V Service only. No Residential Services.

FAIRPORT MUNICIPAL COMMISSION

400A 120/240 Volt

Single Phase Residential Service

12/2/2004

Page 1 of 1

- Compression type lugs are to be provided by the contractor.

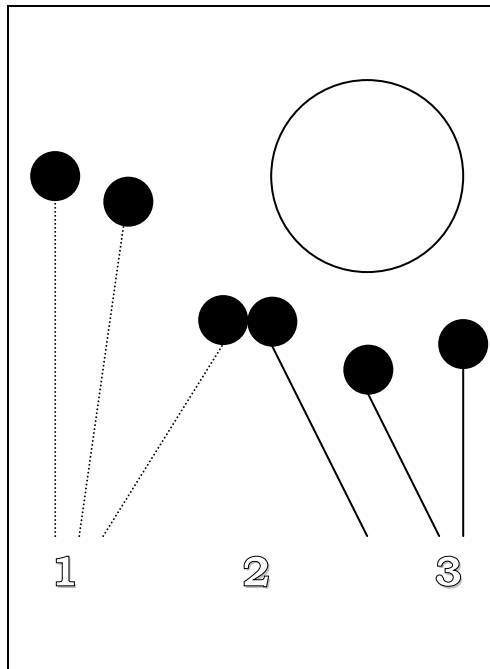

Knockout location 1 to be used for line side:

Direct Buried Services: Customer to sand pad parallel triplex's, install frost loop, and then install parallel triplexes into One (1) 3" (min.) PVC conduit

Conduit full length: Customer to install one (1) four (4) inch PVC conduit full length from FMC distribution point to a three (3) inch (Min.) reducing coupler at the meter socket.

Knockout location 2 to be used for alternate load side or to accommodate an additional service conduit.

Knockout location 3 to be used for load side:

UG - 12

7/12/2011

Page 4 of 12

METER SOCKET WIRING FOR UNDERGROUND SERVICES

BOTH ENTRANCE "PHASE" CONDUCTORS
ARE LOOPED AND ENTER AT THE TOP
OF THE LINE SIDE LUGS

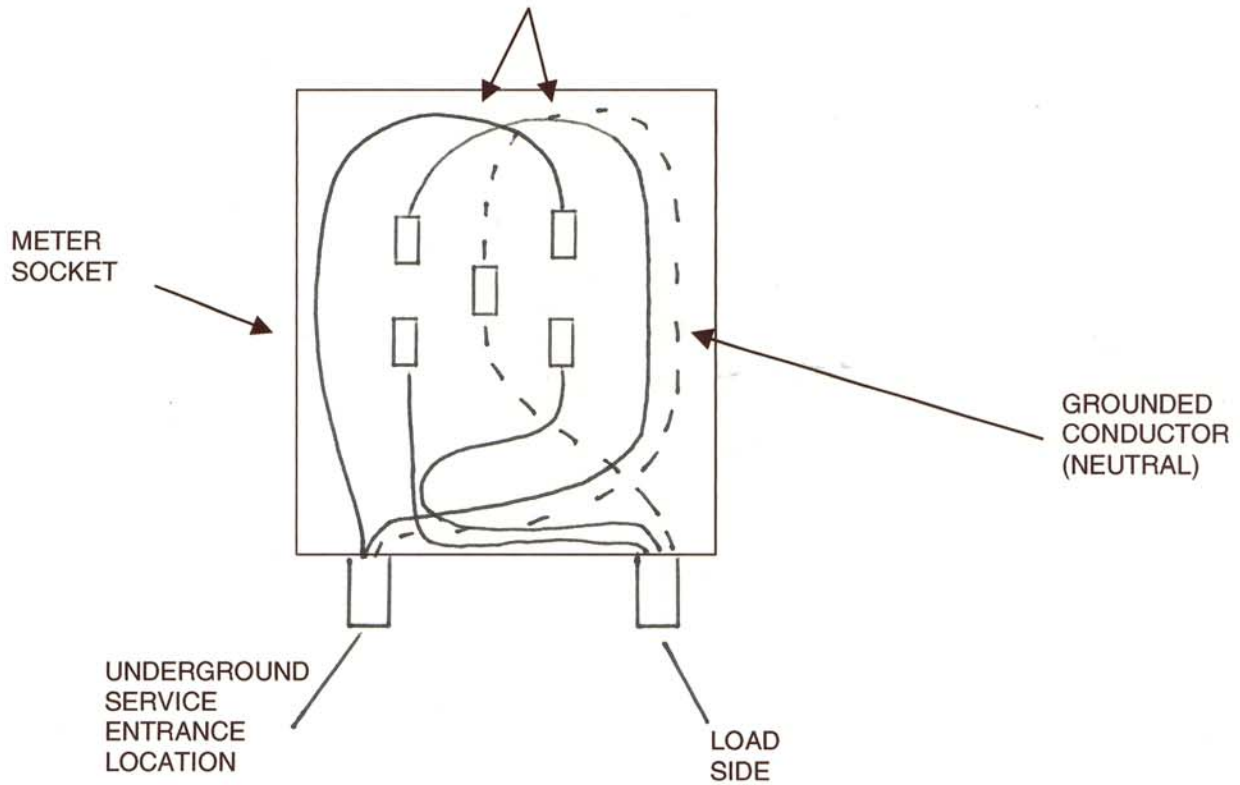

LOOPING OF CONDUCTOR AS SHOWN MINIMIZES
DAMAGE TO CABLE AND STRESS ON CONNECTIONS

All boxes wired 240 volts

5/4/02

7/12/2011

Page 5 of 12

FAIRPORT MUNICIPAL COMMISSION
SPECIFICATIONS FOR SECONDARY UNDERGROUND ELECTRIC SERVICE

1. **The Customer will at his expense install, own, and maintain the service lateral along with the meter box.**
2. The Fairport Electric shall be consulted before work is started to designate the point from which service will be taken, the route to be followed and the meter location. The meter will be spotted by an FMC authorized representative for all service changes. The electrician will need to call 223-9500 at least 48 hours in advance for a meter spot.
3. The customer will provide the trench; install conduits, and backfill in accordance with the following company specifications.
 - a. **SERVICE TRENCH:** Shall be uniform to the required thirty-six inch (36") depth and shall be a minimum of twenty-four inches (24") wide. If joint trench construction is used with other systems (RG&E, RTC and Time Warner), the trench width shall be adequate to permit a minimum of twelve inches (12") separation from other utilities.
 - b. **BACKFILL OF TRENCH:** The first one foot (1') of backfill shall be a stone free bed of sand, six inches (6") below and a sand safety cover six inches (6") above the cable. All sand for bedding and safety cover shall be approved by an FMC representative before placement. The remainder of the trench may be machine backfilled with excavated materials providing no stones, rocks, or debris with any dimension over two (2") inches is included.
 - c. **CONDUIT:** If conduit is used, it must be two and one half inch (2 1/2") minimum pipe size UL approved schedule 40 PVC for all sections under ground and UL approved schedule 80 PVC for all sections above ground or under any paved surface. Galvanized rigid steel conduit can be used in place of PVC. Conduit shall be installed the continuous length of the service and must be inspected prior to backfill. A frost expansion joint is to be provided at the bottom of the meter box for all services.
 - d. **TRENCH INSPECTION:** When the trench is ready for backfill, it will be necessary to call our Service Center (223-9500) and request a trench inspection. A minimum of 24 hours notice must now be given to schedule an appointment for a trench inspection. If we receive an underwriter's approval and find that the trench has already been backfilled, without a trench inspection by an FMC representative, the service will be rejected and will not be connected until it has been re-trenched and inspected in the manner stated above.
 - e. **FROST LOOP:** On direct buried services, a frost loop is required directly below the meter location with a minimum diameter of one foot (1') and a maximum diameter of two feet (2') across the loop.
 - f. **EXPANSION JOINT:** A frost slip joint of two and one half inches (2 1/2") minimum is to be provided at the bottom of the meter box for all services. UL approved schedule 80 PVC must be used for all sections above ground or under any paved surface.
 - g. **GROUNDING:** Shall be per the National Electric Code, grounding will NOT be allowed inside meter enclosures.

UNDERGROUND SERVICE LATERALS FROM OVERHEAD DISTRIBUTION: Customer shall install a ten-foot (10') length of two and one half inch (2 1/2") minimum galvanized steel or schedule 80 PVC conduit, at the pole and sufficient cable to extend from the top of the riser conduit to the FMC secondary conductors plus 5 feet (5'). The FMC will provide and install, the protective covering, necessary cable supports and will connect the cable to the secondary system. Grounding Bushing to be furnished and installed by contractor.

METER SOCKETS: The CUSTOMER will furnish and shall install all meter mounting equipment such as meter sockets. Meters are to be located within a five (5) foot radius of the corner of the house that fronts to the nearest FMC distribution point. All meters are to be located outdoors at a minimum height of 42" and a maximum height of 60". These measurements are to be taken from the center of the meter box to final grade. A fused disconnect must be provided at the meter box if any part of the customers service is buried under any part of the dwelling including the garage if not installed in conduit.

INSPECTION: Service will not be rendered until a certificate of the approval of the customer's wiring from the New York Board of Fire Underwriters, The Commonwealth Inspection Agency, or The Middle Department Agency has been furnished.

DISCONNECT/RECONNECT: Fairport Electric shall DO ALL disconnects/reconnects between the hours of 7:30 a.m. and 3:30 p.m., Monday through Friday excluding Holidays. The customer shall call Fairport Electric (223-9500) to schedule a disconnect/reconnect at least 48 hours in advance.

CONNECTIONS: All connections between Fairport Municipal Wires and customer wires shall be made and removed exclusively by FMC personnel. Connection to the Company's electric supply system or any alteration of existing connections by anyone except Company personnel is PROHIBITED BY PENAL LAW AND PUNISHABLE AS A MISDEMEANOR. VIOLATORS OF THIS RULE WILL BE PROSECUTED. THE LAW PROVIDES THAT THE USER OF SUCH A CONNECTION IS PRESUMED TO HAVE MADE OR CONSENTED TO THE UNAUTHORIZED CONNECTION AND IS PUNISHABLE THEREFORE, UNLESS PROVEN TO THE CONTRARY, AS WELL AS THE PARTY MAKING THE CONNECTION.

FAIRPORT MUNICIPAL COMMISSION
SPECIFICATIONS FOR SECONDARY OVERHEAD ELECTRIC SERVICE

1. **The customer will at his expense install, own, and maintain the service riser up to and including the weatherhead, along with the meter box.**
2. The Fairport Electric shall be consulted before work is started to designate the point from which service will be taken, the route to be followed and the meter location. The meter will be spotted by an authorized FMC representative for all service changes. The electrician will have to call 223-9500 to schedule a meter spot at least 48 hours in advance.
3. CONDUIT: If conduit is used, it must be UL approved galvanized steel conduit two-inch minimum (2") pipe size.
4. GROUNDING: Shall be per the National Electric Code, grounding will NOT be allowed inside meter enclosures.

METER SOCKETS: The CUSTOMER will furnish and shall install all meter mounting equipment such as meter sockets. Meters are to be located within a five (5') foot radius of the corner of the house that fronts to the nearest FMC distribution point. All meters are to be located outdoors at a minimum height of 42" and a maximum height of 60". These measurements are to be taken from the center of the meter box to final grade.

WEATHERHEAD: A rain tight weatherhead must be furnished and mounted above the house knob. Twenty-four (24") inches of wire must be left exposed for a drip loop and power company connections.

INSPECTION: Service will not be rendered until a certificate of the approval of the customer's wiring from the New York Board of Fire Underwriters, Commonwealth Inspection Agency, or The Middle Department Agency has been furnished.

DISCONNECT/RECONNECT: Fairport Electric shall DO ALL disconnects/reconnects between the hours of 7:30 a.m. and 3:30 p.m., Monday through Friday excluding Holidays. The customer shall call Fairport Electric (223-9500) to schedule a disconnect/reconnect at least 48 hours in advance.

CONNECTIONS: All connections between Fairport Municipal Wires and customer wires shall be made and removed exclusively by FMC personnel. Connection to the Company's electric supply system or any alteration of existing connections by anyone except Company personnel is PROHIBITED BY PENAL LAW AND PUNISHABLE AS A MISDEAMEANOR. VIOLATORS OF THIS RULE WILL BE PROSECUTED. THE LAW PROVIDES THAT THE USER OF SUCH A CONNECTION IS PRESUMED TO HAVE MADE OR CONSENTED TO THE UNAUTHORIZED CONNECTION AND IS PUNISHABLE THEREFORE, UNLESS PROVEN TO THE CONTRARY, AS WELL AS THE PARTY MAKING THE CONNECTION.

FAIRPORT MUNICIPAL COMMISSION
SPECIFICATIONS FOR PRIMARY UNDERGROUND ELECTRIC SERVICE

1. **The customer will at their expense install, own, and maintain the primary service.**
2. Fairport Electric shall be consulted before work is started to designate the point from which service will be taken, the route to be followed and the meter location.
3. Customer will provide the trench, conductors, install conduits, and backfill in accordance with the following company specifications.
 - a. **SERVICE TRENCH:** shall be uniform to the required thirty-six inch (36") conductor depth and shall be a minimum of twenty-four inches (24") wide. If joint trench construction is used with other systems (RG&E, Frontier and Time Warner Communications) the trench width shall be adequate to permit a minimum of twelve inches (12") separation from other utilities.
 - b. **BACKFILL OF TRENCH:** The first one foot (1') of backfill shall be a stone free bed of sand, six inches (6") below and a sand safety cover six inches (6") above the conductor. All sand for bedding and safety cover shall be approved by an FMC representative before placement. The remainder of the trench may be machine backfilled with excavated materials providing no stones, rocks, debris with any dimension over two (2") inches is included.
 - c. **CONDUCTOR:** 1/0 A.W.G. 15 KV Primary URD conductor, 19 strand EC grade aluminum conductor, conductor strand shielding, 175 mils cross linked polyethylene or EPR insulation, 30 mils conducting polyethylene layer, 16 #14 or 10 #12 solid coated copper wires uniformly spaced around the conductor. A conductor jacket is highly recommended. Intended for use on single-phase distribution system suitable for direct burial with an ampacity rating of 218 amps, as furnished in accordance with AEIC-5 specifications. Conductor must meet IPCEA and NEMA standards. A two (2) foot piece of the conductor or conductor cut sheet must be delivered to Fairport Electric for approval a minimum of twenty-four (24) hours in advance of the wire being pulled into conduit or direct buried.
 - d. **CONDUIT:** If conduit is used, it must be UL approved schedule 40 PVC for all sections under ground and UL approved schedule 80 PVC for all sections above ground or under any paved surface. Galvanized rigid steel conduit can be used in place of PVC conduit. Conduit must be two and one half inch (2.5") (single phase) and four inch (4") (three phase) minimum pipe size. Conduit shall be installed the continuous length of the service and must be inspected prior to backfill.
 - e. **TRENCH INSPECTION:** When the trench is ready for backfill it will be necessary to call the FMC Service Center (223-9500) and request a trench inspection. A minimum of 24 hours notice must be given to schedule a trench inspection. If FMC receives an underwriter's approval and find that the trench has already been backfilled, without a trench inspection by an FMC representative, the service will be rejected and will not be connected until it has been re-trenched and inspected in the manner stated above.

UNDERGROUND SERVICE LATERALS FROM OVERHEAD DISTRIBUTION: Customer shall install a ten-foot (10') length of galvanized steel conduit at the pole and sufficient cable to extend from the top of the riser conduit to the FMC primary conductors plus 10 feet (10'). FMC will provide and install, the protective covering, necessary cable supports and will connect the cable to the primary system.

METER SOCKETS: Customer will furnish and shall install all meter mounting equipment such as meter sockets and current/potential transformer enclosures for three phase installations. Meter heights from the center of the box to final grade shall be a minimum of 42" and a maximum of 60". Current transformers and potential transformers if needed are furnished by the FMC, but installed by the customer.

TRANSFORMER VAULT: Customer shall furnish and install a transformer vault on bed or compacted material of bank run gravel or equivalent in a location approved by FMC.

Single Phase Service:	FIBERGLASS VAULT
Three Phase Service, 500 KVA transformer or smaller:	CONCRETE VAULT & PAD
Three Phase Service, Transformer larger than 500 KVA:	CONCRETE VAULT & PAD

Customer shall furnish a minimum of two (2) ground rods at pad location placed inside vault.

CONNECTIONS:

1. Customer to supply and make all secondary connections in the transformer.
2. FMC to provide high voltage connections at the pole and transformer.

1/2/96

FAIRPORT MUNICIPAL COMMISSION
SPECIFICATIONS FOR TRANSFORMER VAULTS

1) FOR ALL SINGLE PHASE PAD MOUNTED TRANSFORMERS:

FMC STOCK NUMBER: PAD 5

MANUFACTURERS NUMBER:
FIBERGLASS FABRICATORS 374332SOSHP
ELECTROMOLD INC. EBPT-3743-32A

ALL UNITS SHALL HAVE FOUR OPENINGS FOR
CONDUIT, ONE ON EACH SIDE CENTERED.
ALL UNITS SHALL HAVE FOUR 3/8" X 16
THREADED INSERTS FOR ANCHOR POINTS.

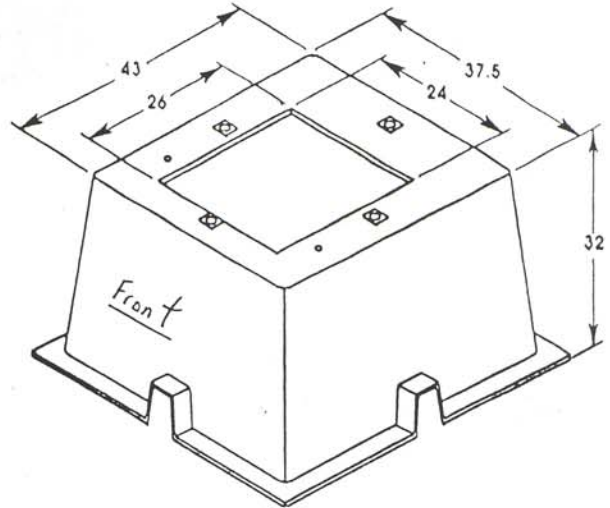

2) FOR ALL THREE PHASE PAD MOUNTED TRANSFORMERS SHALL USE A CONCRETE VAULT.

- 4000PSI CONCRETE AT 28 DAYS
- USE WITH FLAT PADS LARGER THAN 6' X 6'
- KNOCKOUTS 7" X 2', 4 PER SIDE, 4 SIDES
- TO BE SUPPLIED WITH 4 LIFTING HOOKS

FMC STOCK NUMBER: PAD 7

MANUFACTURERS NUMBER: LAKELANDS CONCRETE # FMC-U20

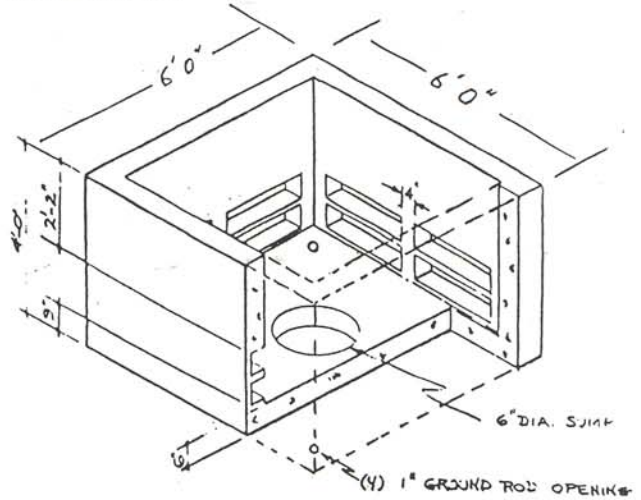

3) FOR ALL THREE PHASE PAD MOUNTED TRANSFORMERS SHALL USE A PAD ATOP A VAULT OF THE FOLLOWING DIMENSIONS.

KVA	A	B	C	D	E	F	G	WEIGHT	FMC#	LAKELANDS #
75-500 KVA	78"	72"	48"	15"	10"	15"	15"	2700	PAD 3	FMC - P33
> 500 KVA	89"	75"	50"	17"	10"	19.5"	19.5"	3100	N/A	FMC - P34

- REINFORCED WITH GRADE 60 - #4 RODS ON 6" CENTERS
- CHAMFER STRIP 3/4" ALL TOP EDGES INCLUDING OPENING
- TOP TO BE PARALLEL WITH BOTTOM
- TOP AND BOTTOM TO BE SMOOTH FINISH
- 4000 PSI CONCRETE AT 28 DAYS

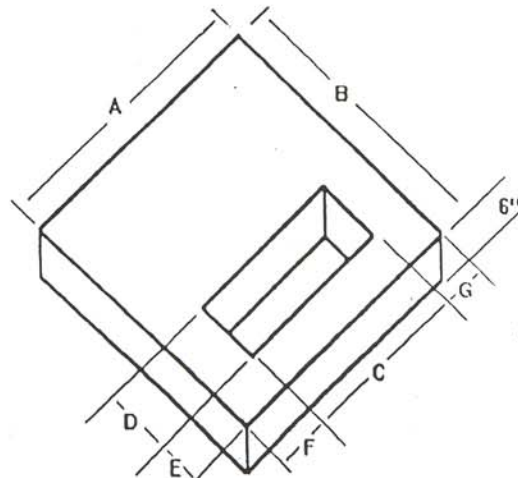

FAIRPORT MUNICIPAL COMMISSION
PRIMARY METERING:
METER LOCATION AT CONCRETE VAULT

07/21/04

Page 1 of 1

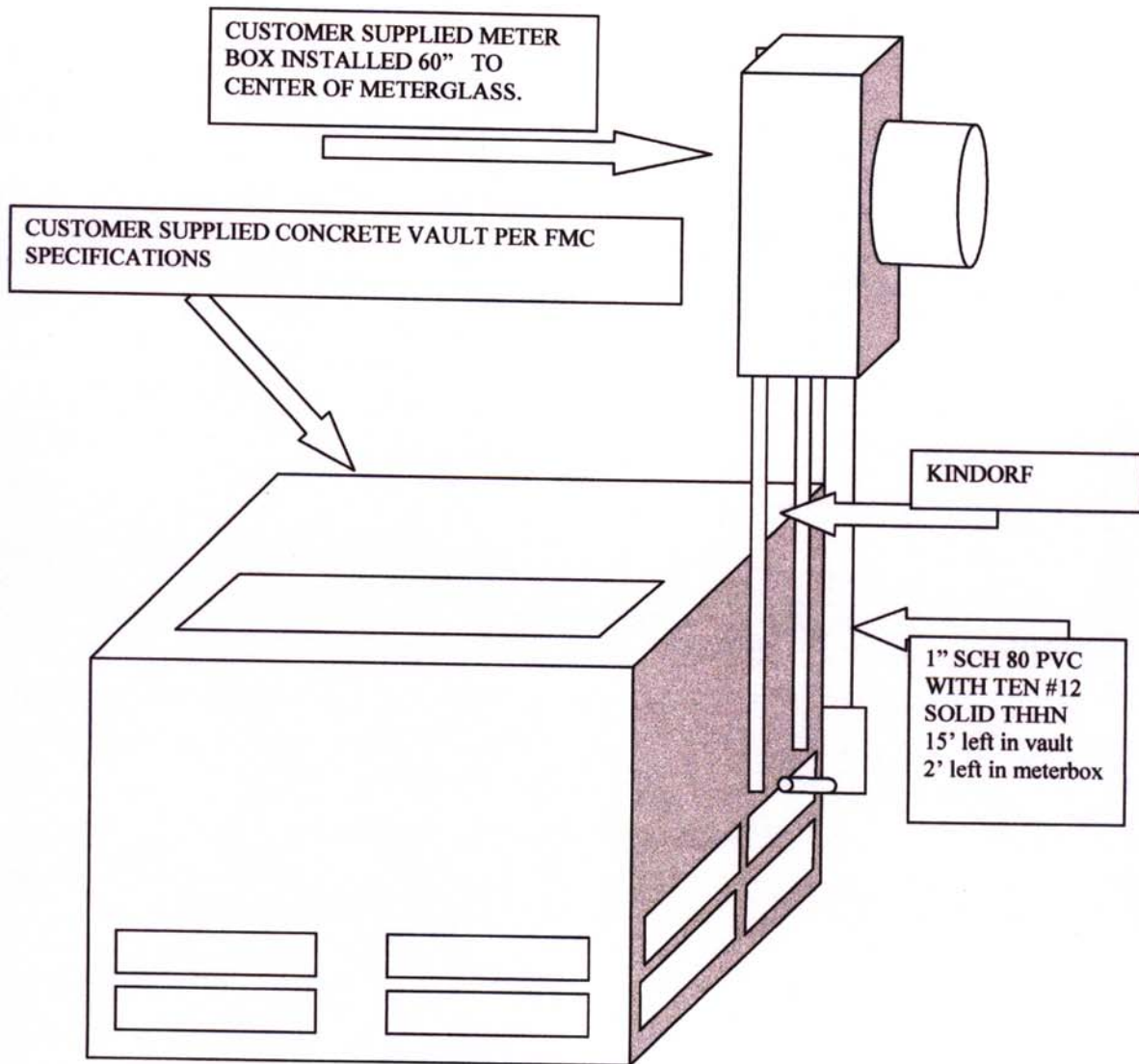

UG - 10

12/19/2007

Page 10 of 12

7/12/2011

Page 10 of 12

FAIRPORT MUNICIPAL COMMISSION

Transformer Protection Bollards

05/23/01

Page 1 of 1

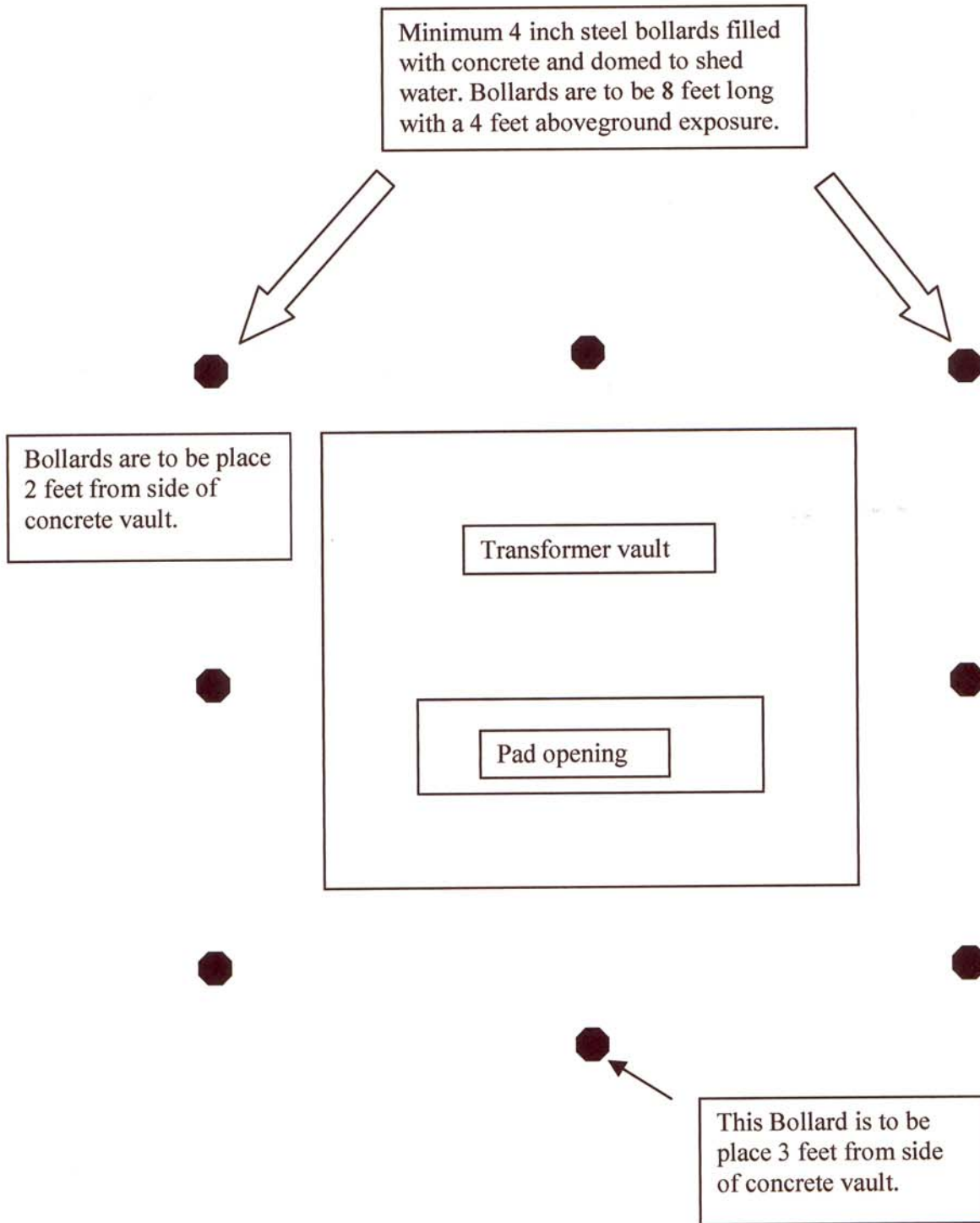

UG - 11

7/12/2011

Page 11 of 12

FAIRPORT MUNICIPAL COMMISSION

Transformer Protection Bollards For Single Phase Transformers

05/23/01

Page 1 of 1

